



RIVKLE® Elastic

Fastener for noise and vibration decoupling applications

BÖLLHOFF

Contents

RIVKLE® Elastic –
Blind rivet nuts for noise and vibration decoupling applications

	Page
The system	3
The principle	3
System versions	4
The advantages	5
Applications in Automotive Industry and General Industry	7
Technical data	8

RIVKLE® Elastic – Blind rivet nuts for noise and vibration decoupling applications

The system

Our design specification was to produce a disconnectable blind rivet fastener with noise and vibration decoupling characteristics.

The solution is the RIVKLE® Elastic blind rivet nut.

It consists of a metric threaded metal insert captured in an elastomer or thermoplastic elastomer body.



The principle

The RIVKLE® Elastic is an innovative solution for fastening load-bearing threaded inserts in thin-walled components and is ideal in applications where noise and vibration decoupling is also required.

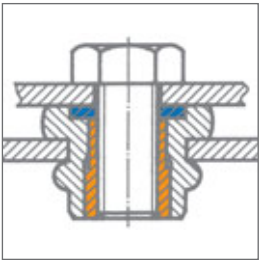

The RIVKLE® Elastic is inserted into the pilot hole from one side of the carrier component.

Clamping nodules beneath the flange secure the fastener in the workpiece prior to assembly. The threaded metal insert (brass on the standard version) is only attached to the body on its lower section so that when the mating screw is tightened this causes the nut body to bulge on the underside of the component to be fastened.

This is a reversible rivet fastening.

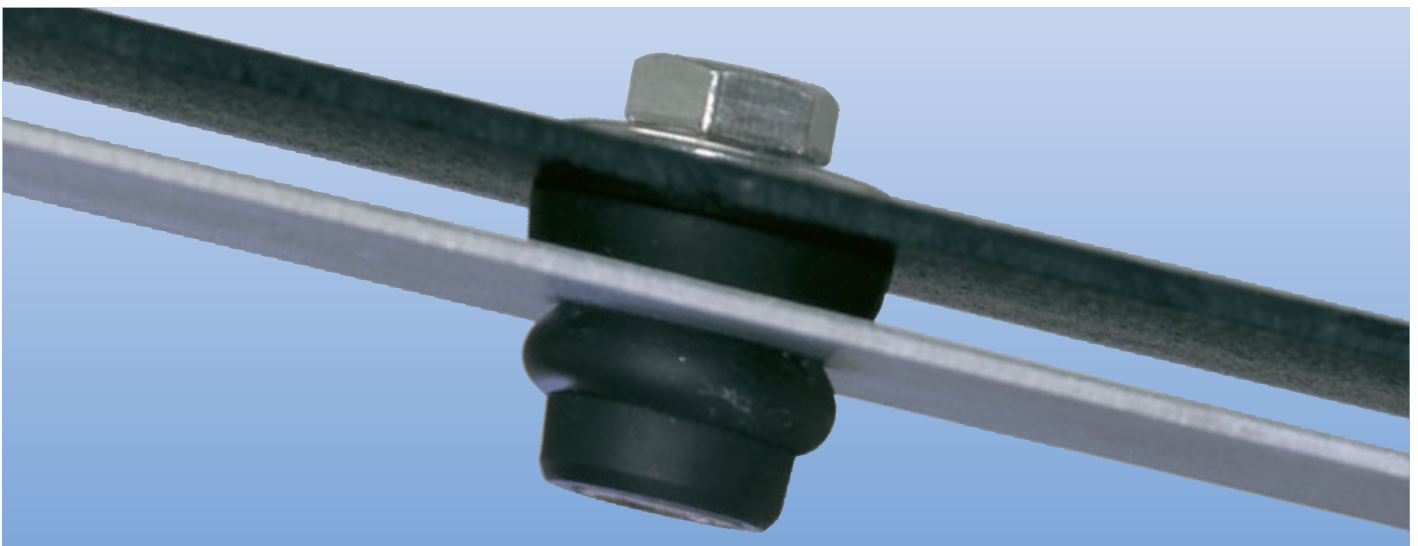

RIVKLE® Elastic – System versions

Standard versions

The standard RIVKLE® Elastic is available in two basic versions.

- RIVKLE® Elastic with washer
- RIVKLE® Elastic without washer

Standard versions are available in four sizes: M4, M5, M6 and M8. Standard versions are available with various shank lengths, shank diameters, metal inserts, thread types, thread lengths, thread diameters, materials and colours. The metal inserts are also available in various materials and surface finishes.

If the component to be fastened is made from steel and has a pilot hole to DIN ISO 273 standard, a RIVKLE® Elastic without a washer should be used. If the component is made from plastic, aluminium or steel and has a slotted hole, a RIVKLE® Elastic with a washer should be used.

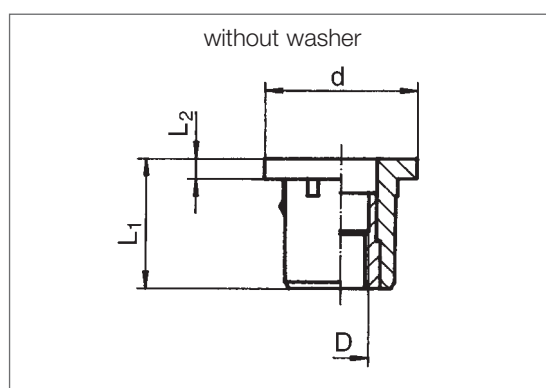
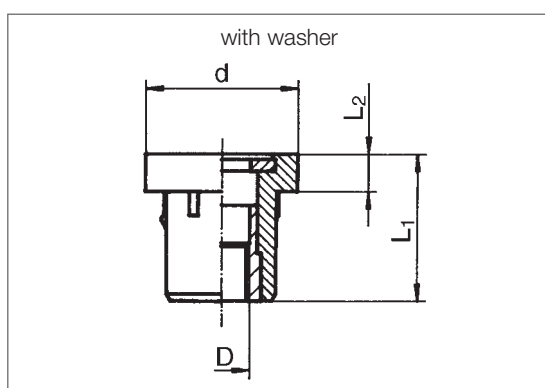

RIVKLE® Elastic HT

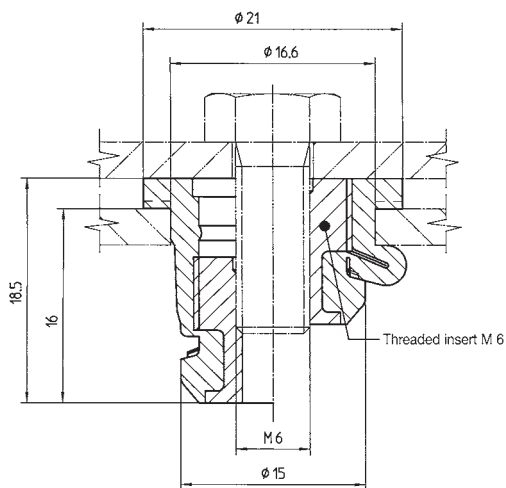

The RIVKLE® Elastic HT is a further development of the RIVKLE® Elastic.

Originally the RIVKLE® Elastic was designed to secure a load-bearing threaded body to a thin-walled component with an additional noise and vibration decoupling property.

Special demands on this joint in terms of continuous operating temperature, tightening torque/loosening torque and tractive load/shear load led to the development of the RIVKLE® Elastic HT. A thermoplastic copolyester elastomer is used in this new decoupling blind rivet nut to meet the special requirements in combination with optimised component shapes.



RIVKLE® Elastic – System versions

Custom versions

In addition to the standard versions we can also manufacture special versions made to customer specifications.

Customers can choose a metal type for the insert which perfectly matches their fastening specifications and other requirements such as strength.

Customers can choose from a range of elastomers and thermoplastic elastomers to ensure that the soft fastener body has the continuous operating temperature, chemical resistance and insulation characteristics required.

Example of special version, underbody mounting

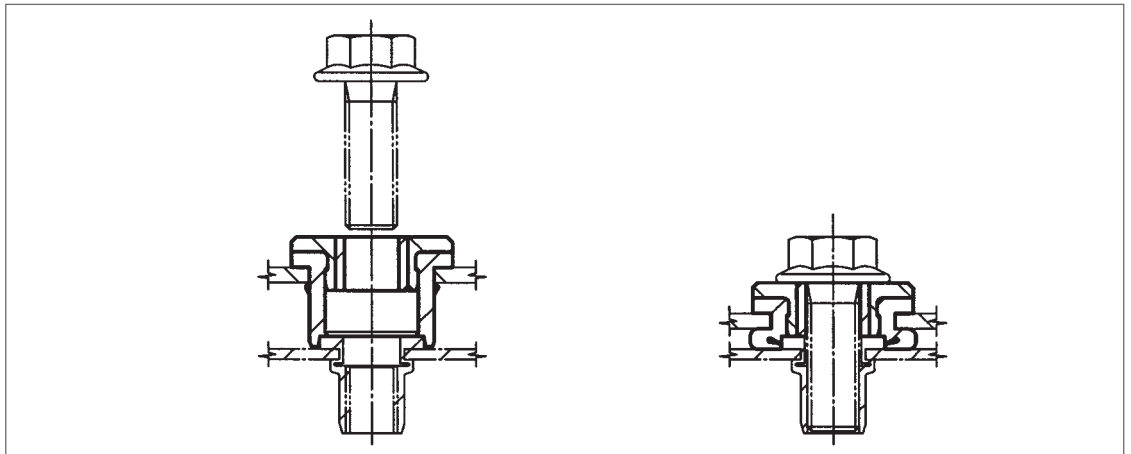

The advantages

- Optimum solution for fastening a load-bearing threaded insert to a thin-walled component
- The only reliable alternative for hollow components, housings and other components where access is only available from one side.
- Blind rivet technology replaces screw fasteners
- Vibration and noise decoupling
- Electrical and thermal insulation
- Tolerance adjustment – Stress relief
 - Stresses caused by manufacturing technology (on component to be fastened)
 - Thermal expansion
 - Dynamic fastener (e.g. moves with the vehicle)
- Easy-to-fit. Setting (bulge clamping) takes place during the screwing process
- Easy-to-dismantle
- Allows full design flexibility thanks to variable parameters

RIVKLE® Elastic – System versions

Materials

Metal insert and washer

Standard versions have threaded inserts made from brass. Inserts made from other metals with different strength specifications are also available. Metal insert bodies are available with all known surface finishes.

The soft part of the fastener is made from various types of elastomer or thermoplastic elastomer depending on the thermal, mechanical and media resistance characteristics required.

The washers on RIVKLE® Elastic fitted with washers are punched from brass and have a zinc-plated surface finish. Other types of washer are available.

Thermoplastic elastomer body

The thermoplastic elastomer bodies of the standard versions of RIVKLE® Elastic are made from TPE-V which has the following characteristics:

TPE-V

- Good mechanical properties in the temperature range -40° C to +120° C
- Good media resistance

A thermoplastic copolyester elastomer is applied for RIVKLE® Elastic HT. The features are as follows:

TPC-EE

- Screw connection up to property class 8.8 possible
 - Continuous operating temperature up to +130° C
 - Diesel oil resistant
 - Damping behaviour in a temperature range of -40° C to +130° C
 - Improved tightening torques/loosening torques
 - Improved tractive and shear load
-

Elastomer body

Two types of elastomer are used on RIVKLE® Elastic with elastomer bodies: VMQ and EPDM. Other types of elastomer (e.g. AEM and ECO) are also available.

VMQ

- Very good thermal resistance from -80° C to +200° C
- Excellent ageing resistance
- High resistance to oil and grease

EPDM

- Very good compression set rating
- Good chemical resistance
- Good resistance to mineral oils and greases
- Continuous operating temperature up to +130° C

RIVKLE® Elastic – Applications

Automotive

- Mounting for engine spoiler and side components
Motorbikes
- Mounting for filters
Passenger cars
- Mounting for compressors
Passenger cars
- Mounting for windblockers
Passenger cars



General Industry

- Heating and air-conditioning
- Electrical engineering and electronics
e.g. fixing of printed circuit boards with electro-static isolation; mounting of sensitive measuring equipment; fixing of switchgear cabinets.
- Agricultural machinery
e.g. tractors, combine harvester...
- Gardening power tools
e.g. lawn mowers...



RIVKLE® Elastic – Blind rivet nuts for noise and vibration decoupling applications

Technical data

■ **Flange**

Part of the RIVKLE® Elastic in contact with the workpiece surface.

■ **Shank**

Part of the RIVKLE® Elastic under the flange.

■ **Clamping nodules**

The clamping nodules secure the blind rivet nut to the work prior to assembly.

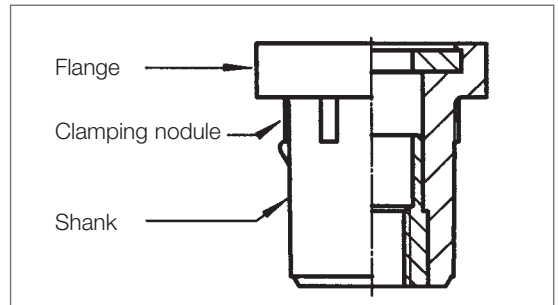

■ **Grip range**

This is the thickness of the material of the workpiece or workpieces where the RIVKLE® Elastic is mounted. The material thickness must be between the minimum and maximum value for the RIVKLE® Elastic grip range.



■ **Pilot hole size**

For round holes this is given by the diameter D_1 .

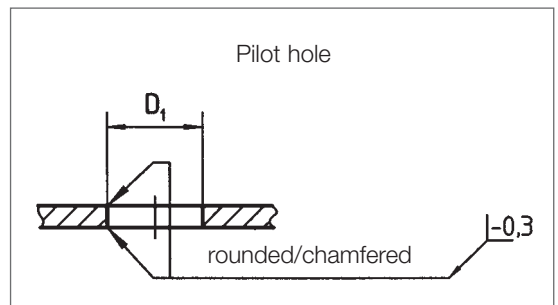

■ **Hole in fastened component**

The size of the hole in the fastened component is given in the DIN ISO 273 (Clearance Fasteners) standard.

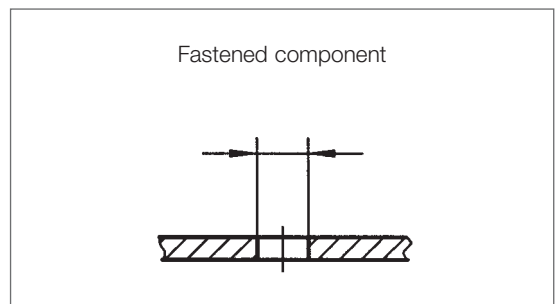

■ **Dimensions after assembly**

The height after setting is indicated by L.

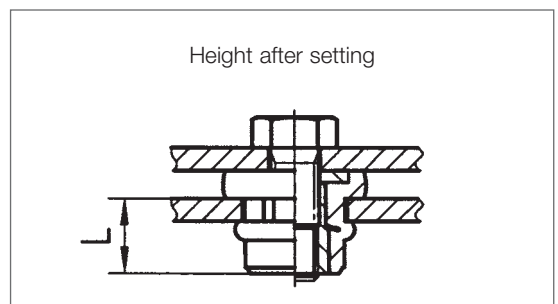

RIVKLE® Elastic – Blind rivet nuts for noise and vibration decoupling applications

Technical data

■ **Mating fasteners**

The RIVKLE® Elastic nut thread is manufactured to standard commercial tolerances (6H as per ISO 68-1). The thread is designed to accept a standard commercial mating fastener and will therefore accept any of the widely available screw fasteners with a 6g tolerance. Rivet nuts can also be manufactured with American and British threads.

■ **Mechanical characteristics – Tightening torque M_A**

Size	Tightening torque M_A max. (Nm)
M 4	2.0
M 5	2.0
M 6	4.5
M 8	7.0

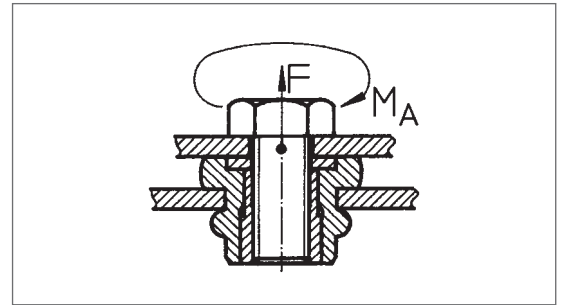

Principle of the evaluation of the tightening torque (RIVKLE® Elastic with washer)

■ **Mechanical characteristics – Axial test load F_A**

Size	Axial test load F_A (N)
M 4	150
M 5	150
M 6	250
M 8	400

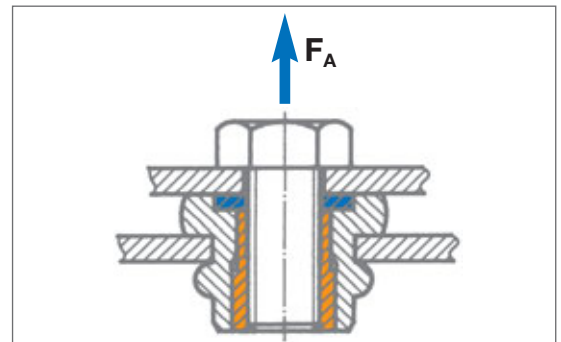

Principle of the evaluation of the axial test load

■ **Maximum clamping bulge deformation (w)**

Size	Max. clamping bulge deformation w (mm)
M 4	15
M 5	15
M 6	15.5
M 8	20.5

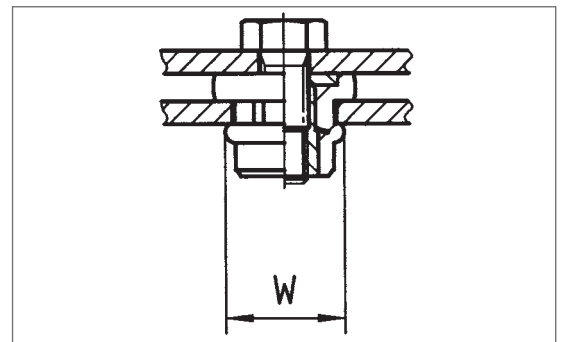

Measurement of the maximum clamping bulge deformation

RIVKLE® Elastic HT

Wall thickness	Dimensions	Tightening torque*	Loosening torque*	Axial tractive load	Shear load
1.2 mm	M 6	M_A (max.) 9.5 Nm	M_L 7.0 Nm	F (max.) 260 N	F (max.) 250 N
3.0 mm	M 6	M_A (max.) 9.5 Nm	M_L 7.0 Nm	F (max.) 380 N	F (max.) 550 N

* Guideline values for screw connection with a screw from property class 8.8.
Measurement for mounting hole \varnothing (type M 6) 16.0 + 0.2 mm

RIVKLE® Elastic – Versions

RIVKLE® Elastic with washer

Material: TPE-V

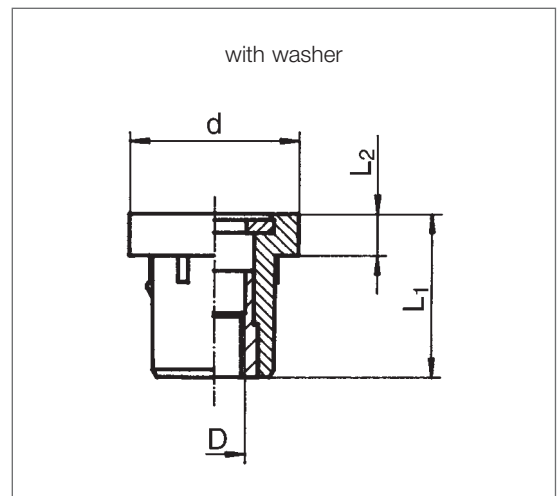

Article no.	Type	D	d	L ₁	L ₂	Hole diameter D ₁	Set length	Grip range
2431 004 0300	with washer	M 4	15	17.7	3.7	10.3 + 0.2	9	0.5 – 3.0
2431 005 0300	with washer	M 5	15	17.7	3.7	10.3 + 0.2	9	0.5 – 3.0
2431 006 0300	with washer	M 6	18	19.3	4.3	13.0 + 0.2	10	0.5 – 3.0
2431 008 0300	with washer	M 8	22	21.6	5.6	16.0 + 0.2	11	0.5 – 3.0

Body: TPE-V, 64 Shore A, black; insert: brass; washer: zinc-plated brass

RIVKLE® Elastic with washer, special version

Insert without thread

Article no.	Type	D	d	L ₁	L ₂	Hole diameter D ₁	Set length	Grip range
2431 362 0300	with washer	6.2	18	19.3	4.3	13.0 + 0.2	10.0	0.5 – 3.0

Body: TPE-V, 55 Shore A, black; insert: without thread

Insert and washer: Material A2

Article no.	Type	D	d	L ₁	L ₂	Hole diameter D ₁	Set length	Grip range
2439 001 0601	with washer	M 6	18	19.3	4.3	13.0 + 0.2	10.0	0.5 – 3.0

Body: TPE-V, 64 Shore A, black

The values given above are correct to the best of our knowledge and are valid as typical standard values.

They are provided as a guide only and must not be used for specifications.

The standard value does not release users from their obligation to test products for their particular uses and production procedures.

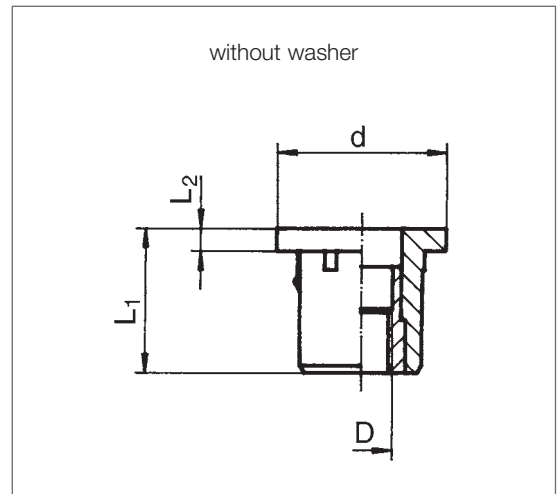
RIVKLE® Elastic – Versions
RIVKLE® Elastic without washer
Material: TPE-V

Article no.	Type	D	d	L ₁	L ₂	Hole diameter D ₁	Set length	Grip range
2430 004 0300	without washer	M 4	15	15.5	1.5	10.3 + 0.2	9	0.5 – 3.0
2430 005 0300	without washer	M 5	15	15.5	1.5	10.3 + 0.2	9	0.5 – 3.0
2430 006 0300	without washer	M 6	18	17.0	2.0	13.0 + 0.2	10	0.5 – 3.0
2430 008 0300	without washer	M 8	22	19.0	3.0	16.0 + 0.2	11	0.5 – 3.0

Body: TPE-V, 64 Shore A, black; insert: brass

RIVKLE® Elastic without washer, special version
Material: Elastomers

Article no.	Type	D	d	L ₁	L ₂	Hole diameter D ₁	Set length	Grip range
2430 206 0300	without washer	M 6	18	17.0	2.0	13.0 + 0.2	10.0	0.5 – 3.0

Body: VMQ, 70 ± 5 Shore A, black

RIVKLE® Elastic HT
Material: TPC-EE

Article no.	Type	D	d	L ₁	L ₂	Hole diameter D ₁	Set length	Grip range
2432 006 0001	without washer	M6	21	18.5	2.5	16.0 + 0.2	8.5	1 – 3

Body: TPE-E, 33 Shore D, black

The values given above are correct to the best of our knowledge and are valid as typical standard values.

They are provided as a guide only and must not be used for specifications.

The standard value does not release users from their obligation to test products for their particular uses and production procedures.

Böllhoff International with companies in:

Argentina
Austria
Brazil
Canada
China
Czech Republic
France
Germany
Hungary
India
Italy
Japan
Mexico
Poland
Romania
Russia
Slovakia
Spain
Turkey
United Kingdom
USA

Apart from these 21 countries, Böllhoff supports its international customers in other important industrial markets in close partnership with agents and dealers.

Subject to technical change.
Reprinting, even in extract form, only permitted with express consent.
Observe protective note according to DIN 34.

Böllhoff Group
Please find your local contact on www.boellhoff.com
or contact us under fasteningtechnology@boellhoff.com

