

AUTOMOTIVE



Door module

Innovative joint solutions
for the door module

BÖLLHOFF

Car

Cars have been manufactured for more than a century. There is no other invention of comparable influence on our life and economy such as the car. It was the car that first granted universal and individual mobility.

Since cars were first invented, there have always been milestones of innovation.



Door

In this overview, the large number of possible uses of our joint solutions and assembly systems are pointed out. By the example of the door module, on the following pages we illustrate a selection of concrete examples from practice.

We join in!

As a leading system supplier for fastening and assembly technology we are a recognised partner for automotive manufacturers and their suppliers.

No matter in which of the car modules you search, you will find one of our solutions there.

Let's start the expedition with the door module.



Door

The following count among the essential functional elements of a vehicle door:

- Door systems
- Window regulators
- Locking systems
- Drives
- Electronic controls

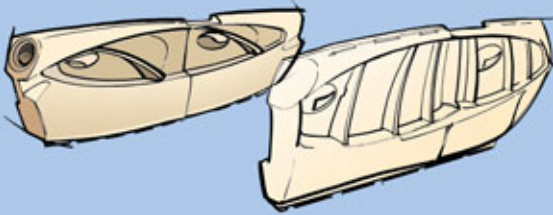

Comfort and aesthetics of the vehicle interior are strongly influenced by the vehicle doors. Ergonomically shaped armrests, functional compartments, easy handling of window regulators and mirrors.

The vehicle doors are an impressive example of integration potential.

The basic division of a vehicle door is the distinction between wet and dry area. The “dry” door half contains all electrical and electronic components while the “wet” half contains all mechanical components. In the door area, there are diverse materials employed – such as thermoplastic high-tech composite materials, metal-plastic hybrid material, etc.

Due to high strengths, doors essentially contribute to the protection of the passengers in case of a lateral impact but also in head-on collision.

Vehicle doors bear much potential for innovative products.

We are happy to join!

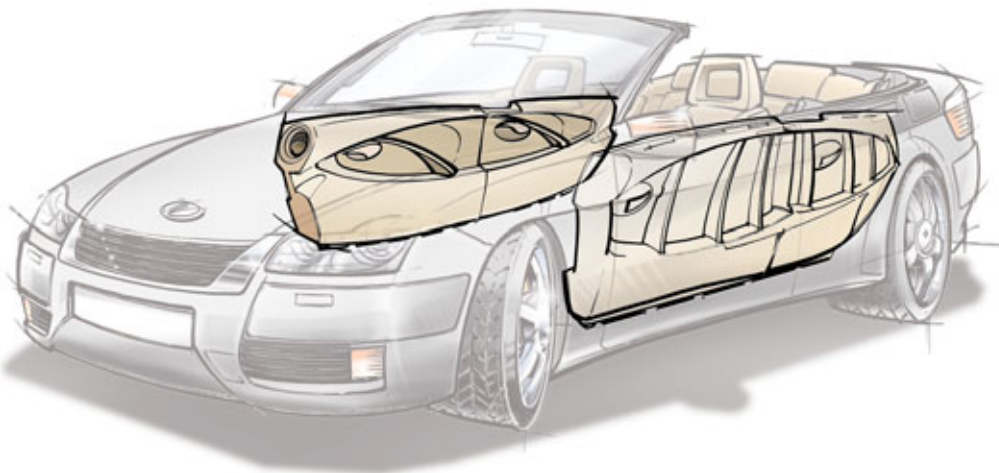

Your joint solutions

the

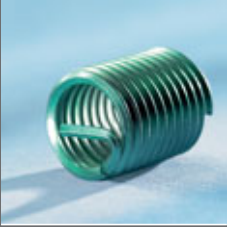

Strong thread?

HELICOIL® – Thread inserts for thread reinforcement in lightweight materials.

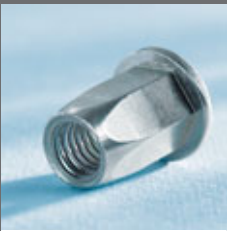

Thin-walled components?

RIVKLE® – The solution for fastening a high-strength nut or stud thread to a thin-walled component.



Threads in plastics?

AMTEC® – Metal inserts for thread reinforcement of plastic parts.



Easy compensation of tolerances?

FLEXITOL® – Systems for automatic compensation of production tolerances.



Snapping and decoupling?

SNAPLOC® – Vibration- and noise-decoupling fastening system.



Screw fastening and decoupling?

RIVKLE® Elastic – A detachable blind rivet joint with vibration- and noise-decoupling function.

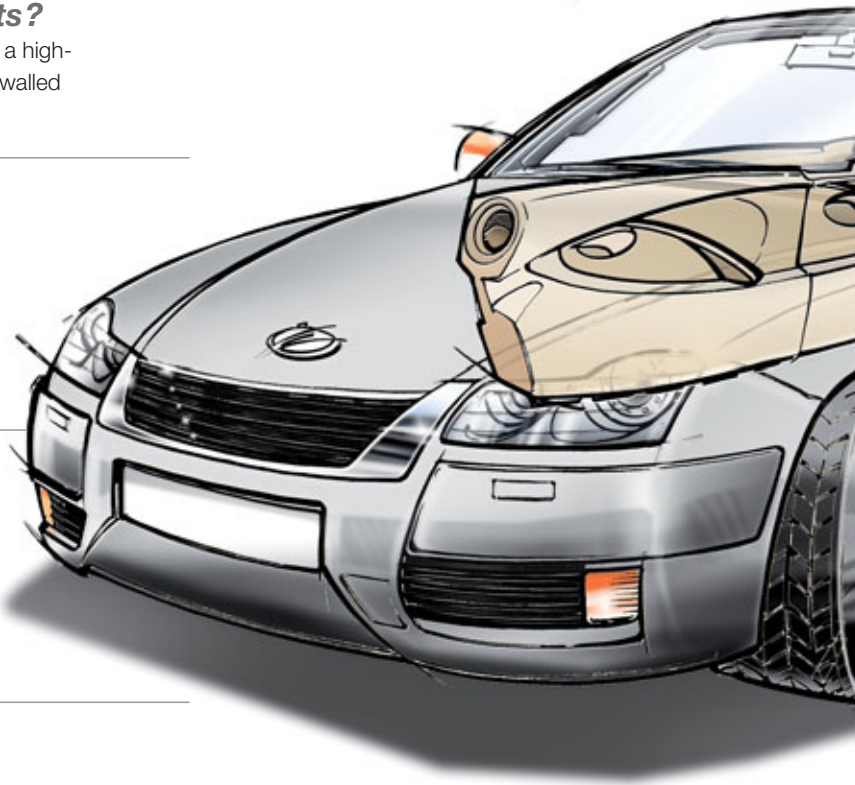

in door module

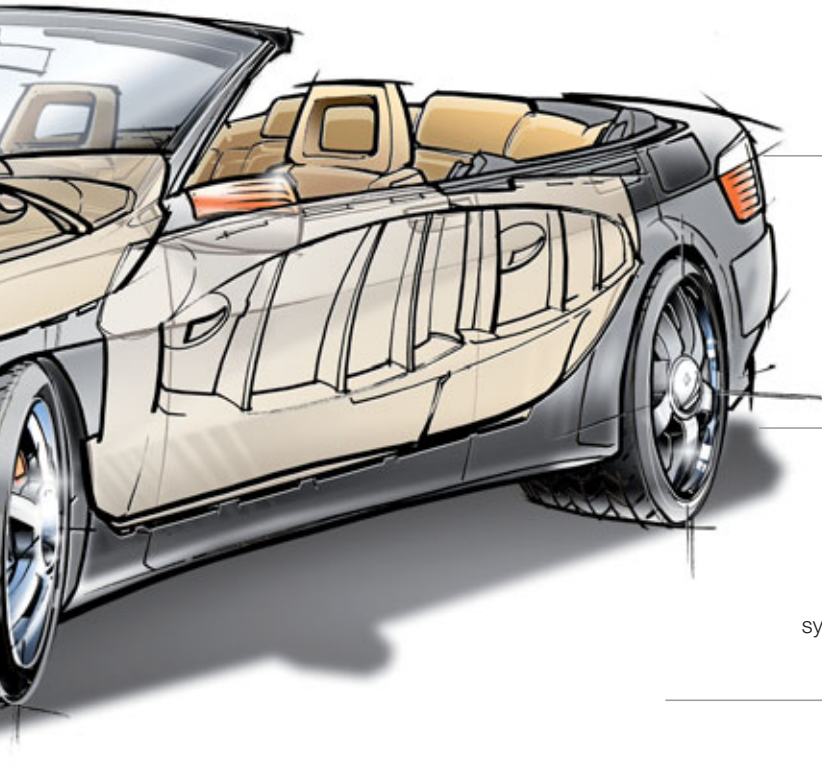

Just in case?

TEPRO® – High-precision technical moulded parts and components.



Direct screw-fitting?

UNITEC® K' in K' (plastic in plastic) – Screws and screw driving systems as a plastic fastening solution.



Easy opening and closing?

QUICKLOC® – Quarter turn pressure locks for quick and repeatedly detachable joints and quick assemblies.

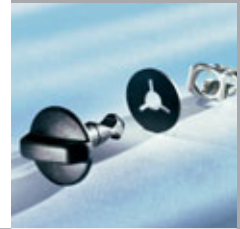

All in one shot?

ONE SHOT – Self-punching fastening system for structural components of fibre-reinforced plastics.



Joining for all purposes?

RIVSET® – High-strength joining of steels, aluminium and plastics without loss of performance.



Assembly of fasteners?

As the leading system supplier in fastening and assembly technology, we also supply the matching assembly solutions for the fasteners.



Fastening of door handle with FLEXITOL®

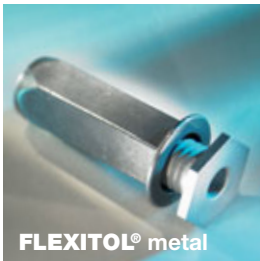

Your advantages – an overview:

- Tension-free installation of the door trim
- Cost reduction upon component production
- Assembly from one side
- Easy installation due to approved blind rivet technology

Especially the automotive industry is ever more becoming a highly automatic assembly industry. High demands on reliable function and quality require smart solutions. This does also apply to the installation of the door handle. Installation must be performed so that the door trim below is evenly fastened.

Nothing easier than that with FLEXITOL® metal. This metal system consists of an adjustment element and a fastening element. In the first step, the tolerance compensation at the door module must be mounted with a RIVKLE® blind rivet nut. After that, the door handle is aligned in the desired assembly position. Upon screwing, the compensation distance between door module and door handle is steplessly and automatically compensated. The friction element serves to move the adjustment element.

The adjustment element is connected to the fastening element via a left-hand thread. While screwing in the screw rightwards, the adjustment element drives out until touching the door handle. Afterwards, the screw is further screwed in until the entire assembly is secured by the screw preload-force. The door trim is thus installed tension-free.

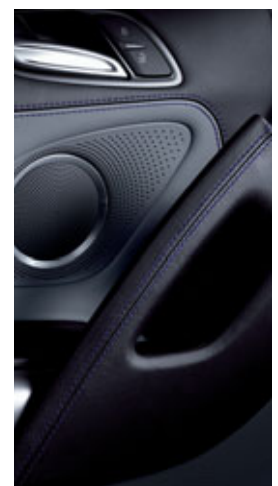
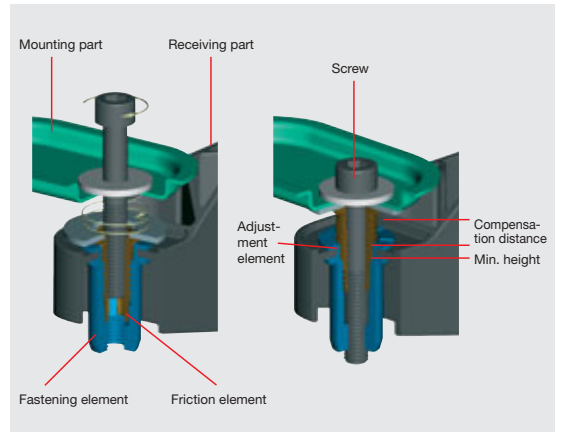

Fastening of door mounting parts with RIVKLE® HRT Aluminium



The HRT process (High-Resistance Thread) resulted from the further development of the RIVKLE® technology. Progressive materials and processes allow to produce a reinforced, hardened thread which considerably improves the mechanical properties of the RIVKLE® blind rivet nut.

This lead in development also pays off when fastening outer and inner door parts to the door frame. In addition, the inner door panel is screw-fastened to the unit carrier.

Usually, these parts are welded. However, welding is not possible for magnesium inner door panels. Screw fastening was the solution found. The installation of the aluminium RIVKLE® HRT blind rivet nut comprises four steps. It is spinned on, inserted into the mounting hole of the outer frame, upset and spinned off. Then, the components can be screw-fastened with an 8.8 screw.

The RIVKLE® HRT aluminium blind rivet nut is the optimal combination of lightweight material and high resistance.

Your advantages – an overview:

- Increased torques allow increased preload-forces in the joint
- Reduced weight
- Corrosion resistance

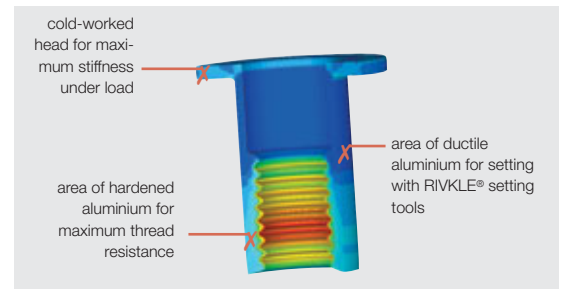

Fastening of window regulator with UNIQUICK® Vario

When installing the window regulator, UNIQUICK® Vario 75 ensures high process reliability and reduced assembly times. It is fastened with 4 x 20 mm AMTEC® screws, 3.5 mm countersunk head.

For screw fastening, two feed stroke screw driving units with a fastening spindle are integrated into a special customer machine. What is so special about this application? Integration in the machine is performed on the inside and outside.

With an electric screw driver, the screw is horizontally/vertically processed. An intermediate cylinder prevents

Your advantages – an overview:

- Fully automatic screw fastening
- Process reliability
- Reduced assembly times

the screw from falling back and thus ensures high availability.

Another example of the high flexibility of UNIQUICK® systems.



Fastening locks with AMTEC®

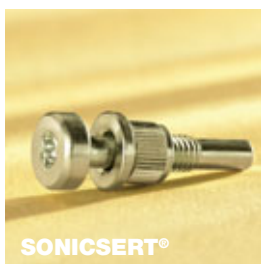

- Your advantages – an overview:**
- Low-stress interference in plastic material
 - No relaxation
 - Assembly advantage



In the area of the door lock, a SONICSERT® compression limiter with an M 5 x 26 captive screw is used. The two-component fastening element consists of a compression limiter and a reduced-shank bolt. To join the screw captively with the compression limiter, the compression limiter is upset after the screw has been inserted. Upsetting results in the formation of an inward bulge in the area of the groove. This is how the screw is mounted captively.

The two-component SONICSERT® fastener is “cold”-inserted into the corresponding drill hole of the bearing bracket (PBT). The longitudinal knurling of the limiter allows easier insertion. After that, the door lock is fastened.

Thanks to this solution, there is no loss of preload upon screw fastening to the through hole.



Fastening to door trim with AMTEC®



- Your advantages – an overview:**
- High-strength and torsion-proof threads
 - Optimum assembly characteristics
 - Retrofitting

The profile of the external thread has an extremely small flank angle and expands asymmetrically towards the thread root. The advantages are most obvious. The slim thread flanks ensure minimum radial tension.

For this application, a possibility to screw-fasten the speaker to the door trim must be provided.

Since retrofitting is required, the QUICKSERT® Hex, a self-tapping bush, is the optimal solution. It consists of a cylindrical basic body with internal thread (M 4) and a special external thread (d 7 | 8 mm).



Fastening of door handle/applique with UNIQUICK® Vario



As the leading system supplier in fastening and assembly technology, we also supply the matching assembly solutions for the fasteners. Screw driving systems and hand-held devices of the UNIQUICK® series ensure maximum precision and process reliability for the installation. From the handy telescopic screwdriver to the special multi-screw driving unit – we adapt our products and services to our customers' supply chains and precisely implement your individual screw driving task.

The stationary UNIQUICK® Vario screw driving system is used for this application. This screw driving system is compact and slim and especially designed for the adaptation into special machines. A feed stroke screw driving system with two fastening spindles was integrated into an existing system at the customer facilities. The special challenge is the assembly of small screws – here the 2 x 6 mm AMTEC® screw with a small counter-sunk head of 3.5 mm. High process reliability ensures the precise coordination of component support and



Your advantages – an overview:

- Fully automatic screw fastening
- Process reliability
- Reduced assembly times

screw driving system (maximum tolerance is 0.2 mm). Screw feed is automatic. Due to the small head-length ratio, screws are directly fed without nozzle jaws. This results in a high availability.

With an electrical screwdriver, screw fastening is carried out vertically from above. The screw driving system is equipped with an integrated control. Interface communication is realised via PROFIBUS (PROcess Field BUS).



For installation, the threaded bush is attached and screw-fastened with a rotating mandrel into the door trim (PP + 50% long fibre) in a self-tapping process. The chosen hexagon socket drive allows efficient cold insertion since spinning on and off is not necessary.

After that, the speaker can be screw-fastened.

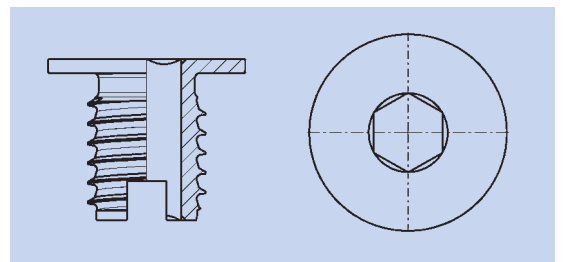

Fastening of speaker with RIVKLE®



Most diverse parts are fastened to the door unit carrier – one of them being the speaker system. To be able to fasten this to an aluminium door unit carrier, RIVKLE® steel blind rivet nuts with hexagonal body – open design – are used. This joint solution creates a high-strength nut thread even on a thin-walled workpiece.

The chosen blind rivet nuts have an extra small counter-sunk head to achieve a very small overflushness. The hexagon design provides for very good screw locking performance.

Another advantage is the economical automatic processing with a CFA 803 (automatic setting head – press principle). The C-frame module was integrated into a complex manufacturing cell (robotic system). The robotic system is so flexible that six different door unit carriers can be processed. Without loss of performance!



Your advantages – an overview:

- Short cycle times
- No wear
- No loss of performance



Fastening of window stop with UNITEC® K' in K'



The screw fastening principle of plastic in plastic (K' in K') is a Böllhoff-specific innovation. For those joints, thread geometry is of decisive importance since K' in K' threads have to self-form or self-tap a "holding thread" into pre-fabricated cylindrical drill holes.

The K' in K' system is characterised by special thread profiles. The different system variants are self-locking, self-tapping, self-forming, adjustable and tolerance-compensating.

An especially developed window stop absorbs noise when the window is stopped. This window stop is fastened to the glass plates of the side doors with a self-tapping UNITEC® K' in K' screw.

Rough tolerances of the glass drill hole can be compensated by the circumferential fins on the window stop. A clearance-free fit results from the taper recess of the K' in K' screw. This is possible due to the press fit in the cone of the window stop.

In addition, the K' in K' screw has a reverse lock. With this joint solution, the stop of the window pane is noise-insulated.



Your advantages – an overview:

- Resists shear forces of 600 N
- Reduced costs due to full-plastic solution
- Noise isolation
- Reverse lock



Fastening of door handle and speaker / inner door fastening with AMTEC®

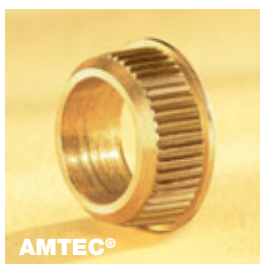

Your advantages – an overview:

SPREDSERT® 1:

- Efficient insertion
- Retaining flange and anchor rings ensure high degree of safety against twist and tensile load
- Screw locking by reaction forces of the slotted body

Compression-Limiter:

- Preload-forces in the joint are maintained – no relaxation of the plastic
- Outside knurling – optimal tight fit in the component

In this application, two Böllhoff joint solutions are employed: special SPREDSERT® 1 M 5 x 9.5 and a compression limiter.

At different fastening points, SPREDSERT® 1 creates a thread to fasten speaker and door handle to the inner door. The thread insert is inserted into the corresponding mounting hole until the retaining flange is completely anchored in the plastic body of the inner door. In that process, the slotted area is compressed. By screwing in a screw, the radially secured SPREDSERT® 1 is forced apart so that the anchor rings (low radial tension) penetrate the plastic and ensure the tight fit of the thread insert. In this process, the screw is locked.

The large flange diameter provides a large contact surface for easier installation. Variations in tolerance of drill hole diameters in the fastened component can now easily be handled.

Loss of preload?
We also have an answer to this question – the compression limiter.

It minimises the loss of preload-forces in existing screw connections with through hole.

The knurled external geometry of the element is anchored in the component and therefore results in an optimal tight fit in the component (inner door). The inner door can now be easily fastened to the door frame.

Principle

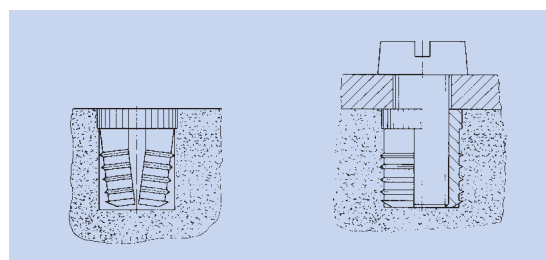

Fastening of door handle with RIVKLE®



Your advantages – an overview:

- Splash-proof
- Damage-proof
- Easy and economical installation



For fastening the door handle, the closed version of an M 5 RIVKLE® blind rivet nut is used.

The closed version bears the advantages of sealing against splash water and avoiding damage from use of too long screws. In this process, riveting is also carried out by a robotic system. The door unit carrier is picked up by the robot and transported to the corresponding installation location. After that, feeding and riveting are performed. An additional high-strength nut thread on

the thin-walled unit carrier results. The door handle can then be installed. With cycle times of 3.5 seconds, an extremely high productivity can be achieved. Feeding and riveting are possible in all positions, even overhead.

This tool can be used for large series with high quality standards. Rely on it!



Fastening of door handle with RIVKLE®



Your advantages – an overview:

- Tolerance compensation
- Easy and economical installation
- Processable in every production step

handle afterwards, a blind rivet nut with an extra large flat head was chosen. This flat head allows screw fastening through a slotted hole.

Riveting is performed automatically.

As a partner for development and production of fasteners, Böllhoff elaborates a great number of application-specific designs.

An M 5 RIVKLE® blind rivet nut with an extra large flat head is used to fasten the door handle.

After the blind rivet nut has been installed in the inner door, the door handle is screw-fastened. The handle is inserted with the corresponding fastening points from the inner side of the door through the trim and screw-fastened to the door unit carrier. To re-align the door

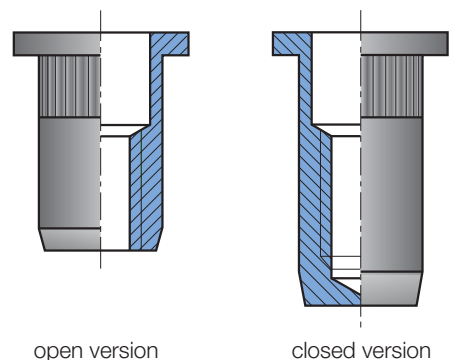

open version

closed version

From A to Z...

A

Requirements

... are we the partner for your projects – from the very first concept to the final realisation.

Our dialogue with you is the thread of our working process. Thanks to smart innovation management and intensively taking your wishes into account we develop tailor-made joint solutions along your supply chain – module after module.

Get to know us in person!

Customer-specific procurement and supply systems to optimise purchase and logistics.



Production with up-to-date technical equipment comprises heterogeneous fields – two of which are plastics engineering and metal working. Benefit from our competent production know-how.



Our expertise in assembly technology reaches from the assembly of component parts to the final product or subassemblies. The production of processing systems perfects our support of your supply chain.





Our project management supports you with management- and product-specific expertise.



To recognise future trends and manage innovations is part of automotive-suitable engineering, as are our own prototype construction and test fields. This way, products can already be optimised in the development phase.



In our own certified laboratory, we carry out mechanical and physical tests as well as chemical material analyses.



Customer orientation – to us this also includes quality- and environment-oriented behaviour. To us – continuous improvement is a constant process.

Certification

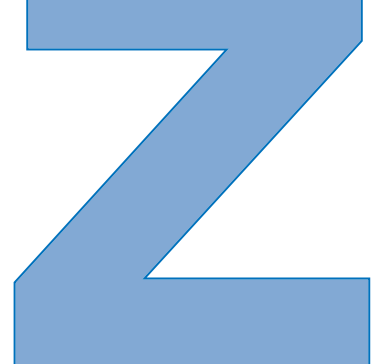

Böllhoff International with companies in:

Argentina
Austria
Brazil
Canada
China
Czech Republic
France
Germany
Hungary
India
Italy
Japan
Mexico
Poland
Romania
Russia
Slovakia
Spain
Turkey
United Kingdom
USA

Apart from these 21 countries, Böllhoff supports its international customers in other important industrial markets in close partnership with agents and dealers.

Subject to technical change.
Reprinting, even in extract form, only permitted with express consent.
Observe protective note according to DIN 34.

Böllhoff Group
Please find your local contact on www.boellhoff.com
or contact us under fasteningtechnology@boellhoff.com

